

WL-VBE

Vapour Barrier Extender for Wall Lights
Recessed Lighting

Job Information		
Project Name		Type
Location		
Quantity		Date
Contact/Phone		
Notes		

Features

General Features

The body is constructed from a membrane with flat flange all around to better enclose fixture from insulation. Rated max. 90°C.



Description

Vapour barrier extender for use with LED in-wall lights in insulated exterior wall applications to prevent moisture from entering into the fixture.

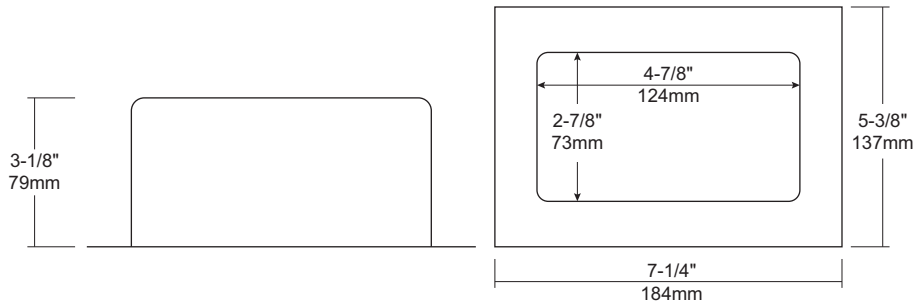

Notes: For additional options please consult your Liteline representative. Due to our continued efforts to improve our products, product specifications are subject to change without notice.

Ordering Guide



WL-VBE

Vapour barrier extender for use with wall lights.